

Wireless Sensor Network for Performance Monitoring of Electrical Machine

Priyanka Ranaware*, N.D. Dhoot**

* Department of E&TC, RMD Sinhgad School of Engineering, Pune, India

** Department of E&TC, RMD Sinhgad School of Engineering, Pune, India

Article Info

Article history:

Received Jun 13, 2014

Revised Sep 13, 2014

Accepted Oct 2, 2014

Keyword:

Condition monitoring
Wireless sensor network
ZigBee

ABSTRACT

This paper proposes a novel industrial wireless sensor network for industrial machine condition monitoring. To avoid unexpected equipment failures and obtain higher accuracy in diagnostic and prognostic for the health condition of a motor, efficient and comprehensive data collecting, monitoring, and control play an important role to improve the system more reliable and effective. A novel wireless data collection for health monitoring system of electric machine based on wireless sensor network is proposed and developed in this paper. The unique characteristics of ZigBee networks such as low power, low cost, and high flexibility make them ideal for this application. The proposed system consists of wireless sensor nodes which are organized into a monitoring network by ZigBee protocols. A base station and wireless nodes have been developed to form a prototype system. Various sensors have the capability to monitor physiological as well as environmental conditions. Therefore proposed system provides a flexible solution that makes our living spaces more intelligent.

Copyright © 2015 Institute of Advanced Engineering and Science.
All rights reserved.

Corresponding Author:

Priyanka Ranaware,
Department of E&TC,
RMD Sinhgad School of Engineering,
Pune, India.
Email: priyankaranaware924@gmail.com

1. INTRODUCTION

On-line health monitoring of electric machine is an important means to prevent motor from unexpected failures to improve the system reliability and maintainability [1]. As we know modern industrial plants are often composed of various machines. The unexpected breakdowns of a single machine not only incur property damage of machine itself but also cause more economic loss due to the interruption of plant operation. Traditionally, data collecting/monitoring system is realized in wired systems formed by communication cables and various types of sensors [2]. The cost of installation and maintenance these cables and sensors are more expensive than the cost of the sensors themselves.

To overcome the restrictions of wired sensor networks, using wireless sensor networks for data collecting/monitoring is proposed. Wireless sensor network is a new control network that integrates sensor, embedded computer, wireless communication and distributed intelligent information processing technology. Its self-organization, adaptability and flexibility topology of network can greatly enhance reliability of health monitoring system.

ZigBee is a new wireless networking technology with low power, low cost and short time-delay characteristics. Based on ZigBee network communication technology, the system can deal with the various operating parameters of the remote transmission, real-time data collection, and real-time health monitoring system. This paper proposes and develops a ZigBee base wireless sensor network for real-time health

monitoring of electric machine. Experimental results demonstrate the capability of the proposed wireless sensor network to investigate different operating conditions such as electrical faults and mechanical faults.

Many papers have been written concerning condition monitoring of electrical machines. The major faults of electrical machines can broadly classify as follows:

- Stator faults
- Abnormal connection of stator windings
- Broken rotor bar or cracked rotor end rings

There are various parameters that can be monitored to check condition of machines such as vibration signal, temperature, current, voltages, etc. Out of which Vibration and current analysis is a remote, not intrusive way to test the electrical machine being monitored. It is based on the analysis of the vibration and current waveform using complex mathematics.

Here the induction motor is taken as an example due to its wide use in industrial processes.

2. THE PROPOSED NETWORK SYSTEM DESIGN

The proposed system of condition monitoring comprises of sensor nodes, a base station and a remote PC. Sensor nodes are responsible for collecting analog data from machine. After processing, they transmit those data to the base station through ZigBee. A base station then repackages that data and transmits it to the remote PC.

A. IEEE802.15.4 Standard

IEEE 802.15.4 standard [3] defines the protocol and interconnection of devices via radio communication in a personal area network (PAN). It operates in the ISM (Industrial, Science and Medical) radio bands, at 868 MHz in Europe, 915 MHz in the USA and 2.4 GHz worldwide.

Based on the IEEE802.15.4 physical layer there are three industrial wireless network standards, ZigBee, WirelessHART, and ISA 100.11a.

ZigBee is a specification for low-rate wireless personal area networks [4]. ZigBee is widely used in many wireless monitoring and control application domains due to its low cost, low power, and implementation simplicity. ZigBee can work in a non-beacon-enabled mode using unslotted Carrier Sense Multiple Access/Contention Avoidance (CSMA/CA) or a beacon-enabled mode using slotted CSMA/CA with or without guaranteed time slots (GTSs). GTSs can be allocated by the network coordinator to devices which require specific bandwidth reservation [4].

WirelessHART is a wireless mesh network communication method designed to meet the needs for process automation applications. The time slots of WirelessHART are of fixed length, 10 ms each, and organized by the superframe. Frequency hopping on a packet-by-packet basis and channel blacklisting techniques are used in WirelessHART to enhance the system robustness. As an interoperable standard, WirelessHART provides an easy way to set up, operate, and maintain a WSN. In addition, it is compliant with the existing highway addressable remote transducer (HART) devices and systems. However, there were no commercial battery-operated WirelessHART development systems available at the time that our work was undertaken.

ISA 100.11a is a wireless system standard for industrial automation, which is intended to provide reliable and secure wireless operation for noncritical monitoring or control applications in industrial applications. ISA100.11a adopts a hybrid medium access control layer, which combines time division multiple access and CSMA/CA. The time slots of ISA100.11a are flexible with configurable length, which provides more flexibility for different system requirements. Frequency hopping and channel blacklisting techniques are also supported in ISA100.11a to ensure the robustness of wireless communications. ISA100.11a can be mixed with existing wired networks, including Modbus, PROFIBUS, Foundation fieldbus, and HART, using tunneling techniques.

However, there are technical challenges to implement the full ISA100.11a stack architecture on low-cost hardware.

Considering the flexibility, convenience of implementation, and availability of low-cost hardware, IEEE 802.15.4 and ZigBee protocols are used for the radio in this paper.

B. ZigBee Based System Framework

The system framework for data collecting/monitoring system based on wireless sensor network is shown in Figure 1. It is made up of data collection nodes and PAN network coordinator. The data collection nodes on this proposed system include sensors for current and vibration.

We are able to set up a network node in several nearby collection points. The nodes can carry out desired functions such as detecting the current/vibration signals, signal quantizing, simple processing, and the ZigBee™/IEEE802.15.4 Standard package framing to transmit data to the PAN network coordinator.

In addition, they can also receive data frames from other nodes, and then adding multi-hop information, package framing, and then transmit the new data frames to the network coordination in the same manner. Once receiving that data via the PAN network coordinator, base station will upload the receiving data to computer for further processing and analysis. An advanced diagnostic/prognostic algorithm will be used to analyze the data to determine the health status of the device and suggest possible measures to mitigate the potential issues. The data can also be linked to the Internet for remote fault diagnosis.

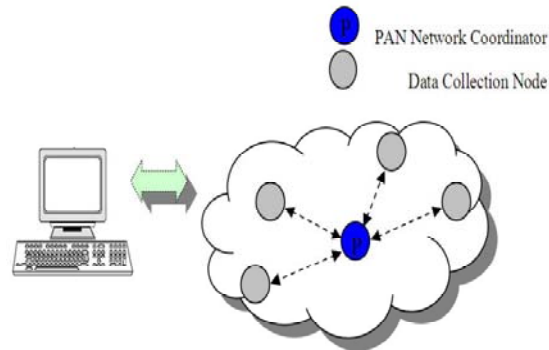

Figure 1. Structure of the Wireless Sensor Network

3. HARDWARE DESIGN OF NODES AND BASE STATION

A network is formed when various sensing devices are deployed at various locations. A Wireless Sensor Network consists of base station and a number of wireless sensors which are simple, tiny in size and a tiny battery powered. Wireless transceivers for wireless devices are reducing in size, less expensive, consumes less power. WSN for home monitoring consists of three modules namely sensor nodes, base station and monitoring PC. Figure 2 illustrates the detailed block diagram of the system.

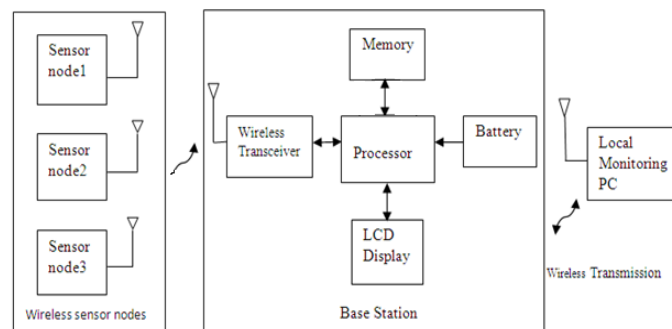

Figure 2. Block Diagram of System

A. Sensor Node

Sensor nodes have limited power, computing and communication capability. Sensor nodes are in charge of collecting information such as current and vibration signal. These signals are usually weak and coupled with noise. First the signal should go through amplification and filtering process to increase the signal strength, and to remove unwanted signals and noise. After which, it will go through an Analog to Digital conversion (ADC) stage for digital processing. The digitized signal is then processed and stored in the processor. Processor will then pack those data and transmit over the air via a ZigBee. ZigBee is used as a transceiver because of its small size, low data rate, low power consumption. Vibration signals are used to detect bearing faults, mechanical faults while current signals are used to detect winding faults.

B. Base Station

The base station hardware is based on processor and responsible for interfacing with the sensor nodes. The data from the sensor nodes are received, processed and transmitted to local monitoring station. The base station consists of various modules such as antenna, transceiver, processor, memory, input unit, display and battery. The sensed data stored in memory as well as transmitted to a monitoring station for further analysis. The RS232 interface is mainly used to establish connections to fixed user terminals, such as the desktop PC and other terminal equipped with serial ports.

4. SOFTWARE DESIGN

A. Communication Design: The Frame Structure of System Network Protocol

IEEE 802.15.4 frame structure of ZigBee protocol is made up of data model, destination address, data length, data information and checkout, the frame format is shown in Figure 3. The first byte is a length byte. The length byte itself is not counted in the length. The frame control field is set according to the IEEE Standard 802.15.4-2006.

| | | | | | | | | |
|----------------|------------------|--------------------|-----------------|------------------|-------------------|--------------------|------------------|-----|
| Octets: 1 | 2 | 1 | 2 | 2 | 2 | 5 | Variable | 2 |
| Length Byte | Frame Control | Sequence number | Dest. PAN ID | Dest. Address | Source Address | Aux.Sec. Header | Frame payload | FCS |

Figure 3. Frame Format

The sequence number is an 8 bit value starting on 0 for the first packet transmitted after initialization. The values of the destination PAN ID, destination address and source address fields are configured by the application as part of the basic RF initialization.

The auxiliary security header is only included in the frames when the security features is used i.e. when the compile option SECURITY_CCM is set in the project file. This field is 5 bytes long and consists of a security control byte that defines the level of protection applied to this frame, and frame counter.

The frame counter field of the auxiliary security header is 4 bytes long and is used for replay protection of the frame. The value of the frame counter field is set to 0 on initialization and incremented for each transmitted packet.

The frame payload is variable in length and consists of data sent from the above layer. The maximum length of this field is 103 Bytes. The Frame Check Sequence field (FCS) is 2 bytes long. This field is automatically appended by the radio chip. When a frame is received the first byte of FCS is replaced with the value in the RX FIFO on the radio.

5. INDUSTRIAL APPLICATIONS

For its excellent performance in reliability and flexibility, the NWSNS has a much more vast range of prospect than the traditional WSN system in industrial application. And in an industrial application, there are some characteristics are desired for a wireless data networks:

- Range: At least a 50m range is required in industrial RF environments. And ZigBee is designed a 10-100m range.
- Data rate: In industrial sensing and control applications required data rates vary widely by application but are often low and intermittent. So the NWSNS should be improved for ZigBee's shortage on high rate transmission in some case.
- Network latency: It varies widely by application. And multi-hop nature of mesh networks increases latency. It should ideally be possible to tune the network availability or response to the application requirement at the end-node to optimize performance. And ZigBee nodes need to wake up very quickly, transmit and/or receive and go back to sleep.
- Power profile: ZigBee has been developed specifically to permit low power consumption and years of battery life.
- Security: At the lowest level: How sure can I be that the data did get from origin to end point accurately and completely ZigBee has security built in. 802.15.4 specifies use of the 128 bit Advanced Encryption

Standard and its specification defines how to handle encryption key change and multi-hop transmission security.

- Operating Frequency: The main requirement here is operation in one of the unlicensed bands for operating cost and regulatory reasons. And ZigBee supports most of the widely used unlicensed ISM bands in Europe, NA, and around the world.
- Network topology: Increasing the number of possible communication paths through the network increases the likelihood that the message will be received at its destination, even if after multiple hops. This makes network traffic more complex but will increase the network resilience and reliability.
- Number of devices: In most real industrial applications many tens, hundreds and possibly thousands of devices could be required in a network. And ZigBee have a great capability to address the spectrum of industrial situations.
- Flexibility: The network technology should be flexible in terms of the uses to which it might be put. It should be agnostic to the type of sensors or output devices attached and able to be implemented for different device types without a lot of device-specific requirements within the network or the protocol stack. And ZigBee is flexible and can carry any type of data.
- Resilience and reliability: It must have the 'Peal world' performance capability to deal with transient interference and obstacles. It must be able to manage and adjust the network configuration, ideally automatic- and know or be alerted when the network encounters a situation that it cannot resolve. During the network implementation it should be possible to design out unnecessary single points of failure. ZigBee is perfect in terms of the range of industrial situations that are likely to be encountered, due to its data packet acknowledgement, CSMA-CA approach, encryption, mesh multi-path transmission redundancy and ability to physically work around the built environment due to the hybrid network configuration options.

6. CONCLUSION

In this paper, the design of wireless sensor network in both hardware and software system for data collecting/monitoring system is presented. Vibration and current analysis is a remote, non-intrusive way to test electrical machine being monitored. Wireless sensor network is a technology with promising future and it is presently used in a wide range of applications to offer significant advantages over wired system. The deployment of Wireless sensor network results in a sensor-rich environment and furthermore constructs a high level intelligent power management system for industrial plants. The motor efficiency and health condition are estimated non-intrusively using only motor terminal quantities through Wireless sensor network without interfering with the motor's normal operation.

REFERENCES

- [1] T.G. Habetler, R.G. Harley, R.M. Tallam, S.B. Lee, R. Obaid, and J. Stack. "Complete current-based induction motor condition monitoring: stator, rotor, bearings, and load". CIEP 2002 VIII IEEE International Power Electronics Congress. Oct. 2002.
- [2] B. Lu, T.G. Habetler, and R.G. Harley. "A survey of efficiency estimation methods of in-service induction motors with consideration of condition monitoring". In proc. 2005 International Electrical Machine and Drive Conference (IEMDC'05). pp. 1365-1372, May 2005.
- [3] J.A. Gutierrez, E.H. Callaway, and R.L. Barrett. "Low-rate wireless personal area networks: enabling wireless sensors with IEEE 802.15.4". IEEE Press, New York. 2003.
- [4] N.P. Mahalik. "Sensor Networks and Configuration: fundamentals, Standards, Platforms, and Applications". New York: Springer-Verlag. 2007.
- [5] Liqun Hou, Neail W. Bergmann. "Novel Industrial Wireless Sensor Networks for Machine Condition Monitoring and Fault Diagnosis". IEEE Transaction on Instrumentation and Measurement. vol.61, no. 10, pp. 2787-2798, Oct. 2012.